

Talon openGear Encoders Dual and Quad Channel

H.265 | H.264 | 10-bit 4:2:2

FEATURES

- Embedded 16 Audio Channels per Input on OG-3G-2E & OG-12G-2E
- Embedded 8 Audio Channels per Input on OG-3G-4E
- **Color Depth 10-bit 4:2:2**
- **HDR (HLG)**
- **NVME Interface for on-board video storage**
- **Embedded Timecode from SDI → Transport Stream (SMPTE12M-2)**
- **SCTE104 from SDI → Embedded as SCTE35 in transport stream**
- Protocols: RTMP(S), UDP, RTP, RTSP, Zixi™, SRT™, WHIP
- Scaling, Frame Rate Conversion, Color Space Conversion, De-Interlacing
- Audio Compression AAC-LC, OPUS
- CEA-708 Closed Caption Support
- **REC 2020, REC 709 Support**
- **SMPTE 2038 Support**
- **Dual GigE Ethernet**, 1x RJ45, 1x openGear Frame (requires Ross Video MFC-OG3-N Advanced Networking Frame Controller)
- JSON REST API
- Secure HTTPS (SSL) web-based management
- OpenVPN and OpenConnect Client
- Whitelist/Firewall for management IP access

* interlaced encoding only supported HEVC point-to-point between Talon Encoder and Talon Decoder

Models:

OG-3G-2E	Dual Channel 3G-SDI (2x 1080P60 Encoding)
OG-12G-2E	Dual Channel 12G-SDI (1x 4K60 or 2x 4K30 Encoding)
OG-3G-4E	Quad Channel 3G-SDI (4x 1080P60 Encoding)

SPECIFICATIONS:

I/O Connections:

- HD-BNC for SDI
- Ethernet #1 RJ45
- Ethernet #2 openGear Frame

Video Formats

- DCI 4K at 23.98/24/25/29.97/30/50/59.94/60 fps (OG-12G-2E)
- UHD 4K at 23.98/24/25/29.97/30/50/59.94/60 fps (OG-12G-2E)
- 1080p at 23.98/24/25/29.97/30/50/59.94/60 fps
- 1080i at 30/25 fps *
- 720p at 25/29.97/30/50/59.94/60 fps
- PAL 576i, NTSC 480i

In the Box:

- OpenGear Card
- Rear I/O Module

Mechanical:

- Density: 18 Cards per OG3 or OGx Frame (20 cards when ordered with customized OGx Frame)
- Compatible with OG-X-FR, OG-3-FR and DFR8321 Frames
- Power consumption: 13W
- Operating Temperature -20C to 60C
- Operating Humidity 5% to 95% non-condensing



openGear is a registered trademark of Ross Video Ltd

Talon openGear OG-12G-2E 4K Encoder

Single Channel Encoding up to 4K60

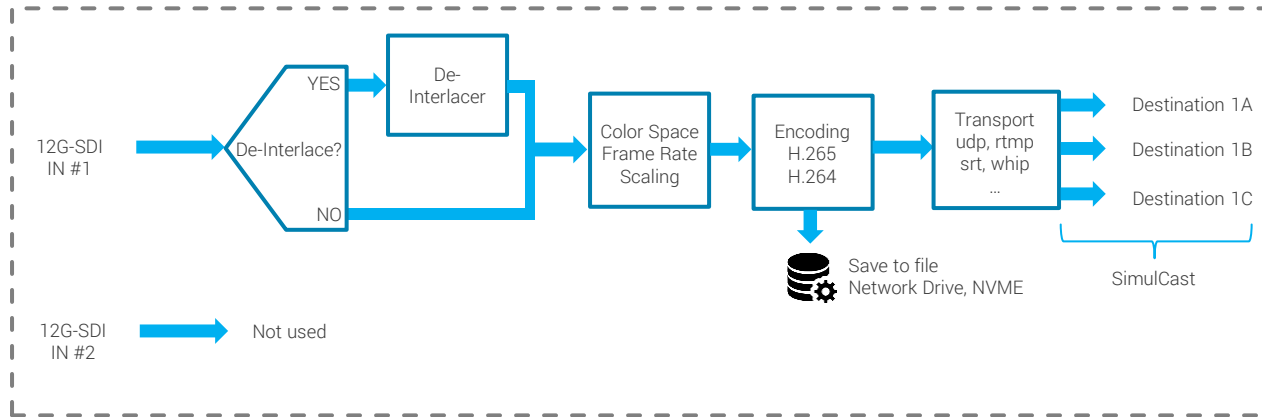

Simulcast:
Multiple streams with identical encode settings but different destination addresses (feature only applies to RTMP)

Dual Channel Encoding up to 4K30 per Channel

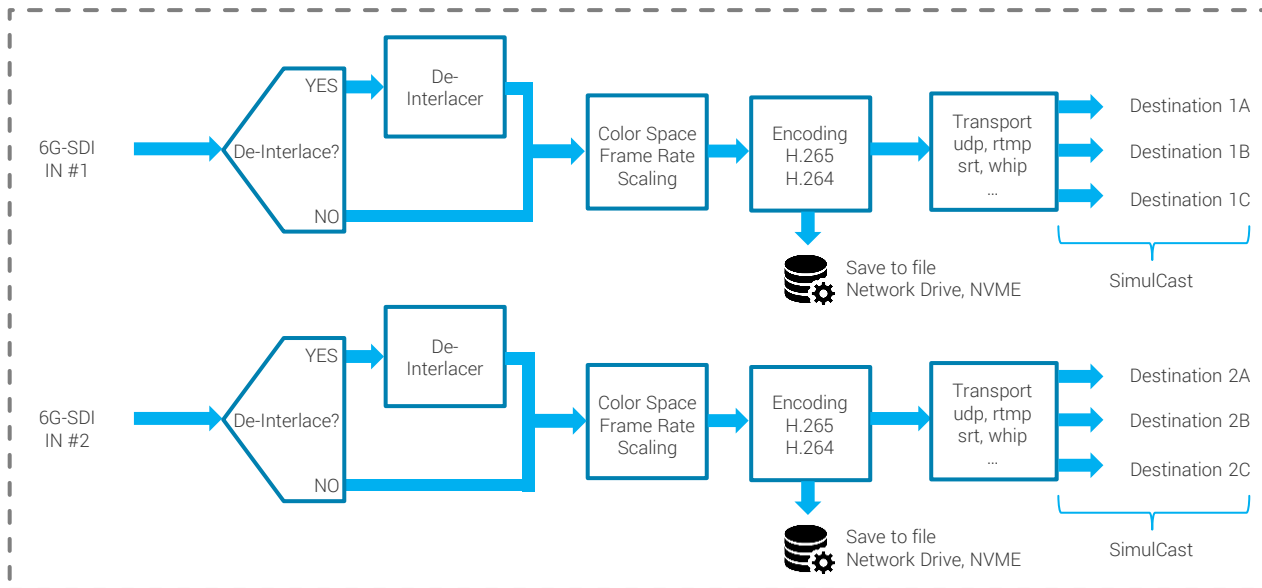

Talon openGear OG-3G-2E Dual HD Encoder

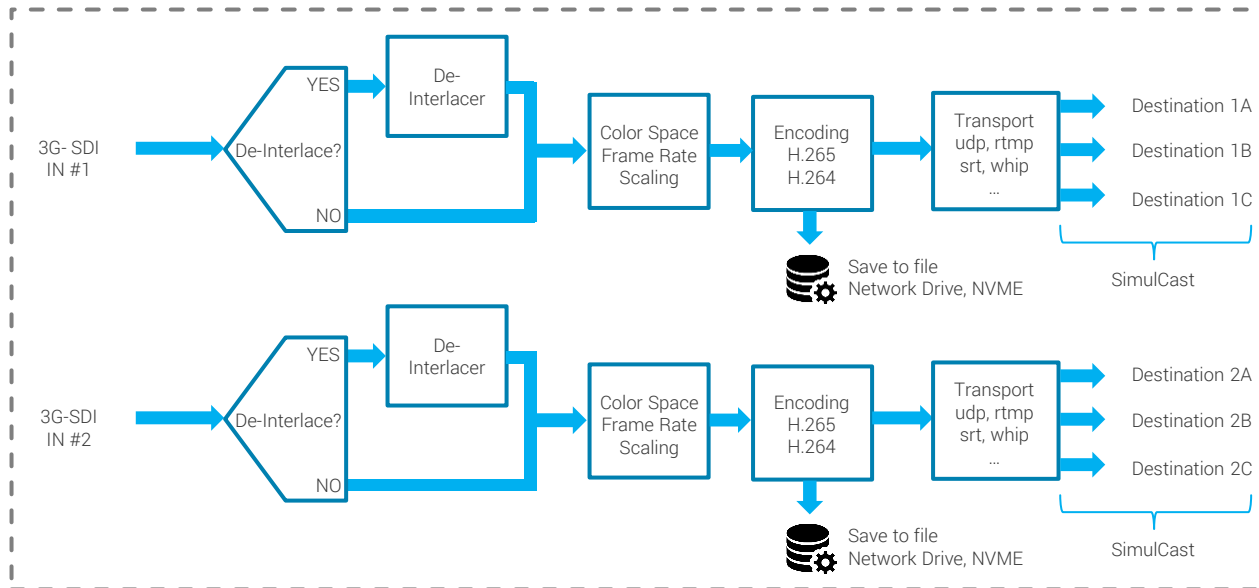

Pipeline supports two 3G-SDI inputs and two encodes up to 1080P60

Simulcast:
Multiple streams with identical encode settings but different destination addresses (feature only applies to RTMP)

Talon openGear OG-3G-4E Quad HD Encoder

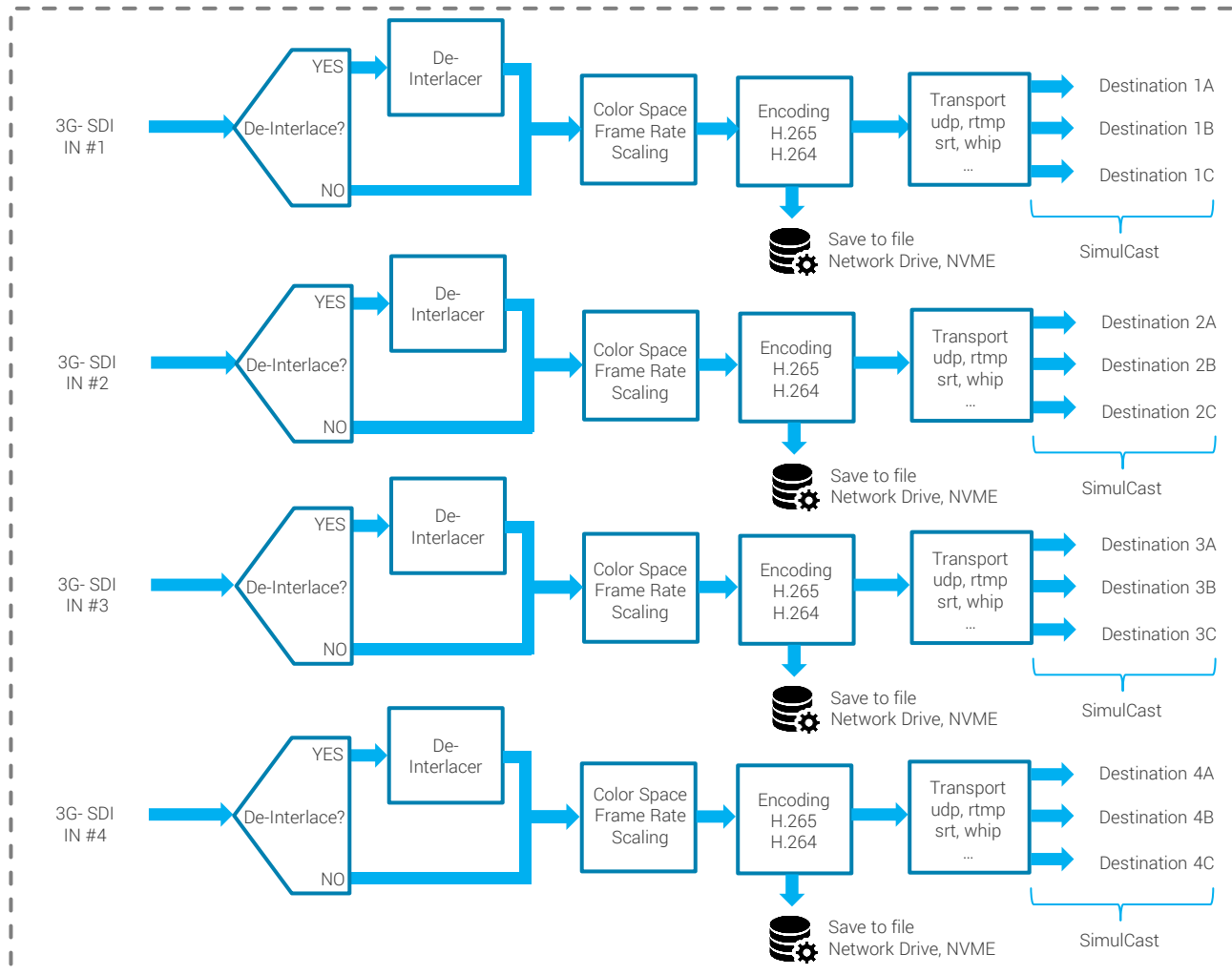

Pipeline supports four 3G-SDI inputs and four encodes up to **1080P60**

Simulcast:

Multiple RTMP streams with identical encode settings but different destination addresses (feature only applies to RTMP)